

Vertical Machining Center

# VP-8/VP-10



## Tongtai Tongtai Machine & Tool Co., Ltd.

### Headquarters

No.3, Luke 3rd Rd., Luzhu Dist., Kaohsiung City 82151, Taiwan

TEL : 886-7-9761588 FAX : 886-7-9761589

www.tongtai.com.tw

Taoyuan Branch	TEL : 886-3-4551399	FAX : 886-3-4559730
Taichung Branch	TEL : 886-4-23589600	FAX : 886-4-23589993
Japan Branch	TEL : 81-4-71438355	FAX : 81-4-71438360
Europe Branch	TEL : 31-161-454639	FAX : 31-161-454768
Romania Branch	TEL : 40-264-415273	FAX : 40-264-403983
Malaysia Branch	TEL : 603-78597113	FAX : 603-78597115
Vietnam Branch	TEL : 84-4-62766090	
Thailand Branch	TEL : 66-2-7443440	FAX : 66-2-3986518
Indonesia Office	TEL : 62-21-45850875	FAX : 62-21-45850876

### China Operation Center

#### Shuzhou Tong-yu Machine & Tool Co., Ltd.

No.555 Huahong Rd., Economic Development Zone of Wujiang, Suzhou City, Jiangsu Province, China

TEL : 86-512-63430168

FAX : 86-512-63431622

E-mail : sales@tong-yu.com.cn

Wuhan Branch	TEL : 86-27-59409109	FAX : 86-27-59409110
Chongqing Branch	TEL : 86-23-67865925	FAX : 86-23-67867717
Guandong Branch	TEL : 86-755-27222119	FAX : 86-755-27222115
Tianjin Branch	TEL : 86-22-24417640	FAX : 86-22-24416738
Shanghai Office	TEL : 86-21-24208138	FAX : 86-21-34073262
Shenyang Office	TEL : 86-24-24142968	FAX : 86-24-24115782

### Affiliates

<b>Honor Seiki Co., Ltd.</b>	<b>Asia Pacific Elite Corp.</b>	<b>Quick-Tech Machinery Co., Ltd</b>	<b>PCI-SCHEM - rue Copernic</b>	<b>ANGER Machining GmbH</b>
TEL : 886-7-9759888	TEL : 886-4-23589313	TEL : 886-6-3841155	TEL : 33-4-77426161	TEL : 43-7229-71041-0
FAX : 886-7-9759999	FAX : 886-4-23588913	FAX : 886-6-3841177	FAX : 33-4-77426023	FAX : 43-7229-71041-199
www.honorseiki.com.tw	www.apecnc.com	www.quicktech.com.tw	www.pci.fr	www.anger-machining.com



# VP-8/VP-10



- The VP Series vertical machining centers produced with a high quality direct-drive spindle, a high speed tool changer, and high rapid traverse. With many excellent features that makes an ideal machine for various industrial requirements.
- High quality spindle and high rigidity structure design subject to high standards of machine accuracy to achieve good cutting performance.
- By Tongtai Production System, we check every detail process from design, manufacturing, assembly and QC.
- The new generation exterior design is elegant and easier than ever to operate.



### Main specifications

Spindle	10,000 rpm BBT-40 Direct-drive type spindle
	10,000 rpm BBT-40 Direct-drive type spindle with CTS
	15,000 rpm BBT-40 Direct-drive type spindle
	15,000 rpm BBT-40 Direct-drive type spindle with CTS
X/Y/Z axis	Rapid traverse VP-8(VP-10) : 48(36)/48(36)/36 m/min
	X/Y/Z axis Travel VP-8(VP-10) : 820(1020)/510/535(600) mm
	X/Y/Z axis adopts high quality linear guideways and ballscrews

#### CONTENTS

- 03 Main structure
- 07 Operator convenience
  - Machining capacity
- 08 Spindle output and torque chart
- 09 Standard/Optional accessories
  - Machine dimension
- 10 Specifications

## Main structure

- Excellent performance/price ratio
- Stable machining precision
- Smarter and reliable standard functions
- Reliable quality
- High production efficiency and stability

### X/Y/Z axis specification:VP-8

#### Travels

X/Y/Z axis 820/510/535 mm

#### Rapid traverse

X/Y/Z axis 48/48/36 m/min

### X/Y/Z axis specification:VP-10

#### Travels

X/Y/Z axis 1,020/510/600 mm

#### Rapid traverse

X/Y/Z axis 36/36/36 m/min

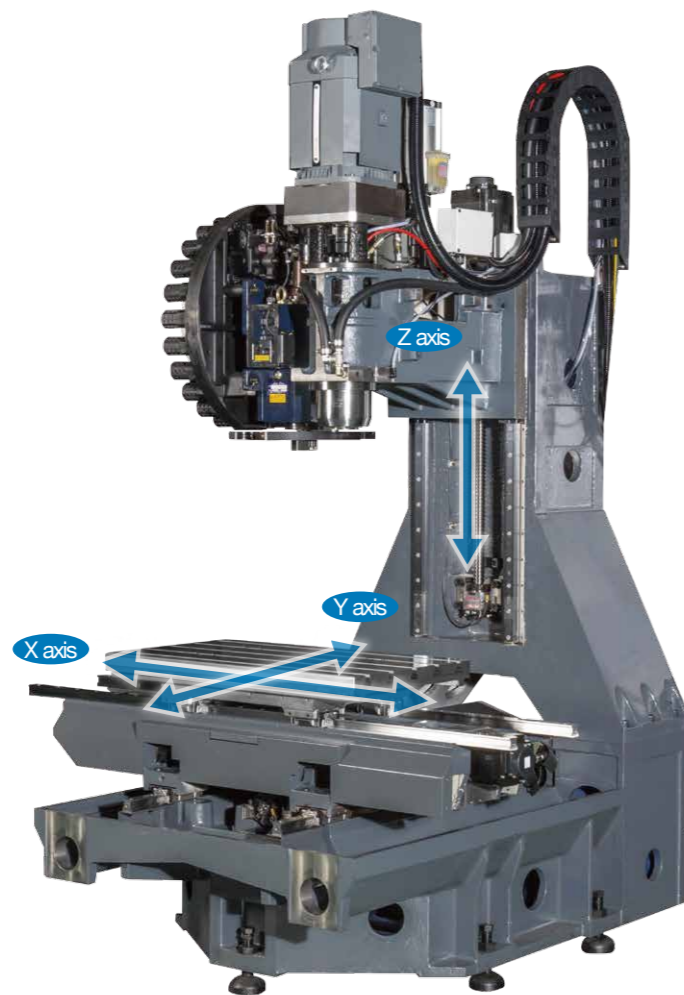

### Working area

#### VP-8

Table size 900 x 510 mm

Max. loading capacity 500 kg

#### VP-10

Table size 1,070 x 510 mm

Max. loading capacity 500 kg

※VP-8(VP-10)

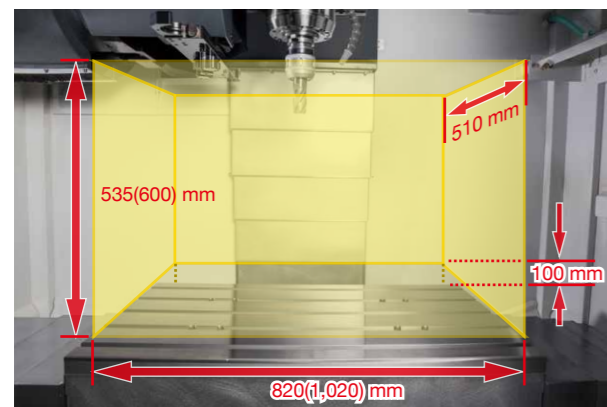

### High-rigidity frame structure design

Our base and column castings feature vibration-absorbing ribs that transfer vibration away from the cutting area.

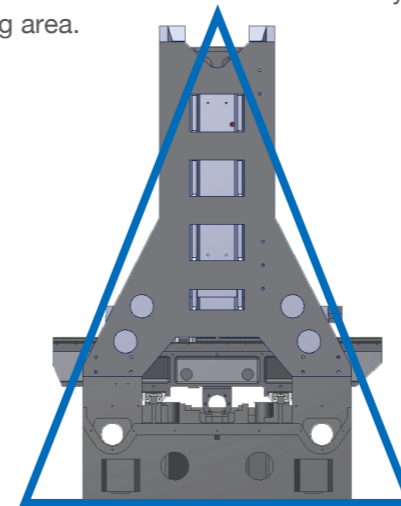

### Finite Element Analysis (FEA)

Advanced FEA is used to simulate various cutting loads. The ribs distribution is optimized and alleviates weight on the machine.

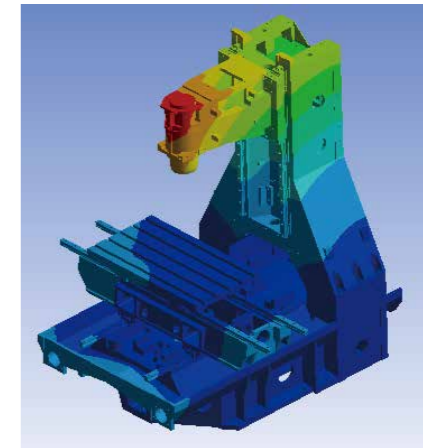

### Linear guideways

VP Series use linear guideways for each axis. Linear guideways are preloaded to provide zero clearance between the moving surfaces. They have a very low coefficient of friction, which allows faster movements without sacrificing repeatability or positioning accuracy.



### Direct-coupled servo motors

Servo motors are coupled directly to the ballscrews with non-backlash steel couplings. This greatly improves positioning accuracy, and provides more accurate threading and contouring. And they don't wear out or lose accuracy over time.

### High quality spindle

- Clamping position sensors send the signals to the machine controller based on the position. (Tool Unclamping / Tool Clamping / Without Tool)
- By employing winding switching, a wider rate output range require for the spindle driving motor of a machine tool is achieved.

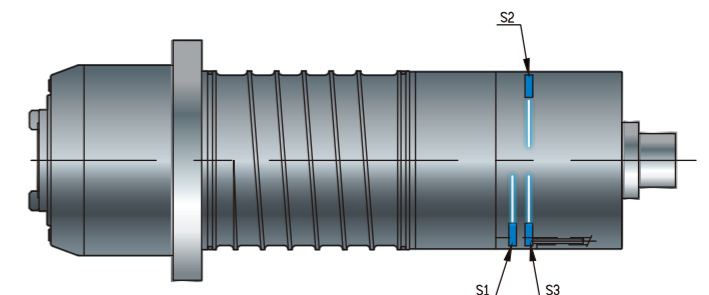

# Main structure

## Ballscrew

The ballscrews are center mounted and supported on both ends by high precision angular contact thrust bearings. This single pre-tension design provides outstanding positioning repeatability with minimized thermal growth.



## Stability

A gap design between column and electrical cabinet to avoid heat transfer.

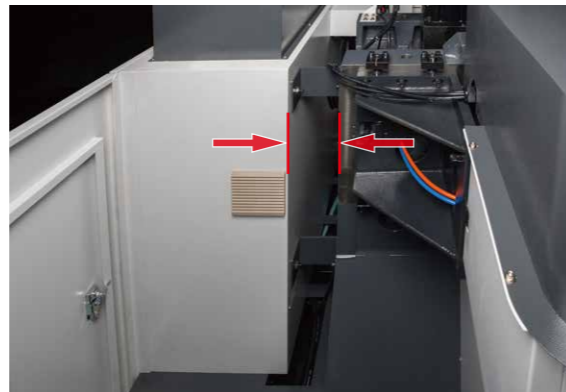

## Safety

Safety glass window, which has passed EN12417 standards and certificated by CE, is adopted for providing excellent protection to the operator. The impact strength is 200 times that of tempered glass. Furthermore, the front door uses the multiple safety window (tempered glass mixes with PC), and is able to extend the usage life.



## Tool management

Standard equipped with stable and rapid tool magazine. The time of T to T is 2.0 sec. and C to C is 3.6 sec. ATC is controlled by inverter, durability and less maintenance are superior than the traditional braking system. (ISO 10791-9)



Thanks to absolute encoder, cam box signal transfer faster and stable. With Tongtai PLC logic setting, ATC will re-try which reduces the possibilities of machine stop when errors happened during tool changing.



## Direct-drive spindle

Direct-drive spindle that is coupled directly to the motor provides high accuracy, high acceleration ability, low vibration, long usage life, and easy to maintain. Flexible coupling prevent the spindle from abnormal heat increment and thermal deformation. Moreover, the customer is able to adopt dual-contact tool holders for getting higher precise machining performances (also available for BT-40).

Max. Speed	Standard	Optional
10,000 rpm (Std.)	BBT-40	CTS
15,000 rpm (Opt.)	BBT-40	CTS

Dual-contact (BIG-PLUS)



## Spindle cooling system (Opt.)

To reduce the thermal displacement, spindle chiller is available as optional equipment, which could automatically adjusted spindle temperature according to machine temperature.

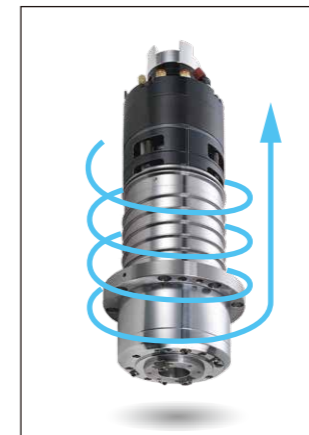

## Coolant through spindle(CTS) (Opt.)

This feature improves the machining process more effectively especially with deep hole drilling operations and at the same time, increasing the tool life.

Coolant through spindle	
Optional	20 bar
	50 bar



## Coolant tank

The large-capacity tray and high-mesh filter prevent chips from entering the coolant tank, and easy to maintain. Chip conveyor is also available as optional equipment.

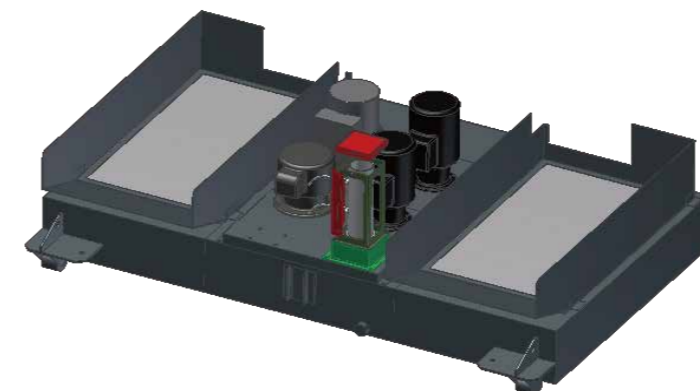

Filter type coolant tank	
Standard	40-mesh filter
	280 L

Conveyor type coolant tank	
Optional	40-mesh filter
	Chain type chip conveyor
	320 L

Accessories	
Optional	Coolant level detection
	Disc type oil skimmer

# Operator convenience·Machining capacity

## Ergonomic design

An easy-to-use operation panel which can swivel from 0-90°.



## Easy to maintain

Controls are on the side panel to facilitate maintenance.



## Machining capacity

Benchmark:  
Mitsubishi: SJ-VK15-28FZT(F) 11/15 kW  
FANUC: αil12/10000 11/15 kW

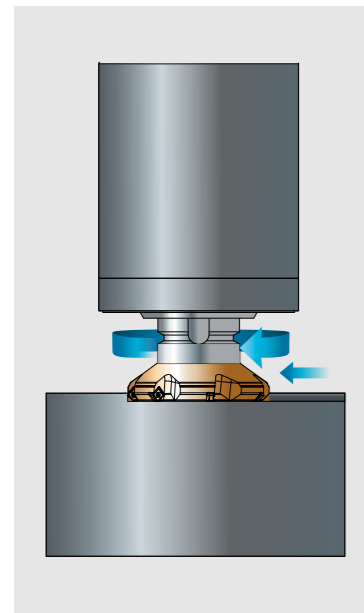

Face mill S45C	
Tool	Ø80x6T
Spindle speed	1,493 rpm
Feedrate	2,240 mm/min
Cutting width	65 mm
Cutting depth	3.2 mm
Chip quantity	465 cc/min

Drill Ø32 S45C	
Tool	Ø32
Spindle speed	248 rpm
Feedrate	0.3 mm/rev
Hole depth	50 mm

Face mill ADC12	
Tool	Ø80x6T
Spindle speed	4,478 rpm
Feedrate	6,178 mm/min
Cutting width	65 mm
Cutting depth	3.8 mm
Chip quantity	1,659 cc/min

  

Tapping M24 S45C	
Tool	M24x3P
Spindle speed	133 rpm
Thread depth	45 mm

Please notice the cutting data is just for reference. Different tools and spindle motors will influence the realistic performance results.

# Spindle output and torque chart

## 10,000 rpm (Std.)

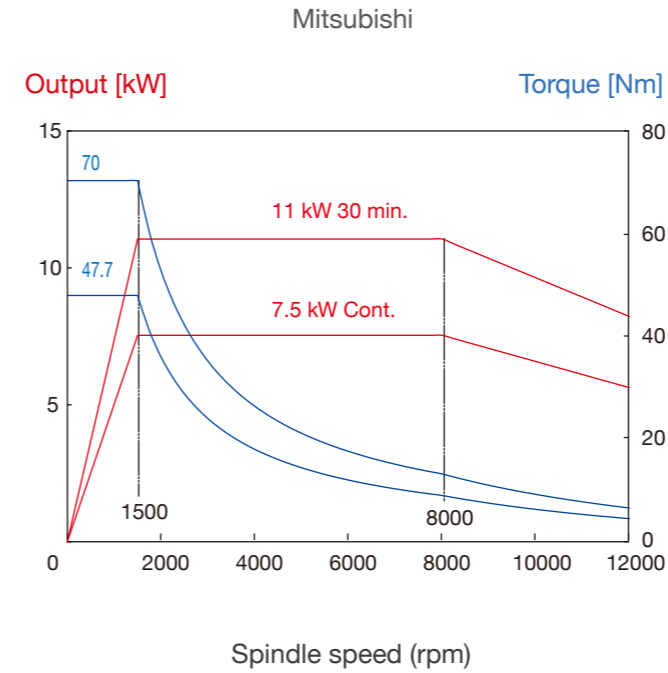

## 10,000 rpm (Opt.)

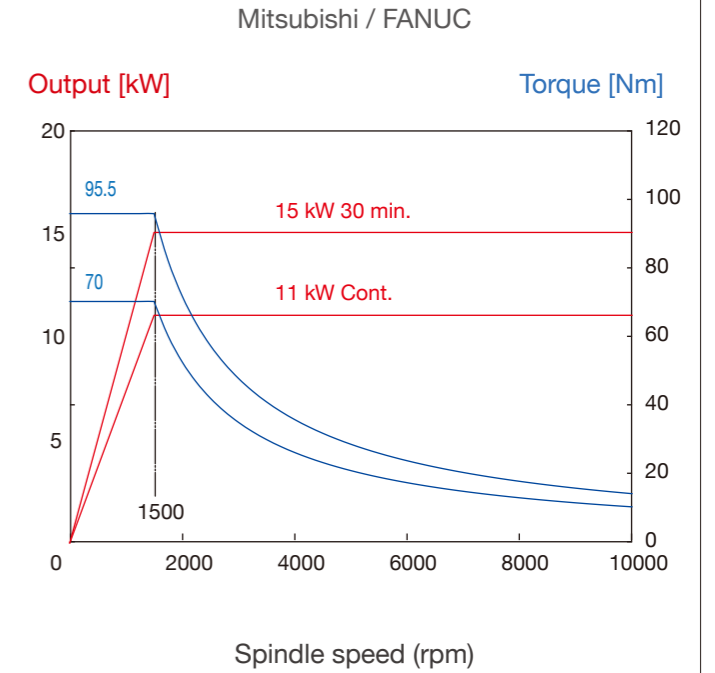

## 15,000 rpm (Opt.)

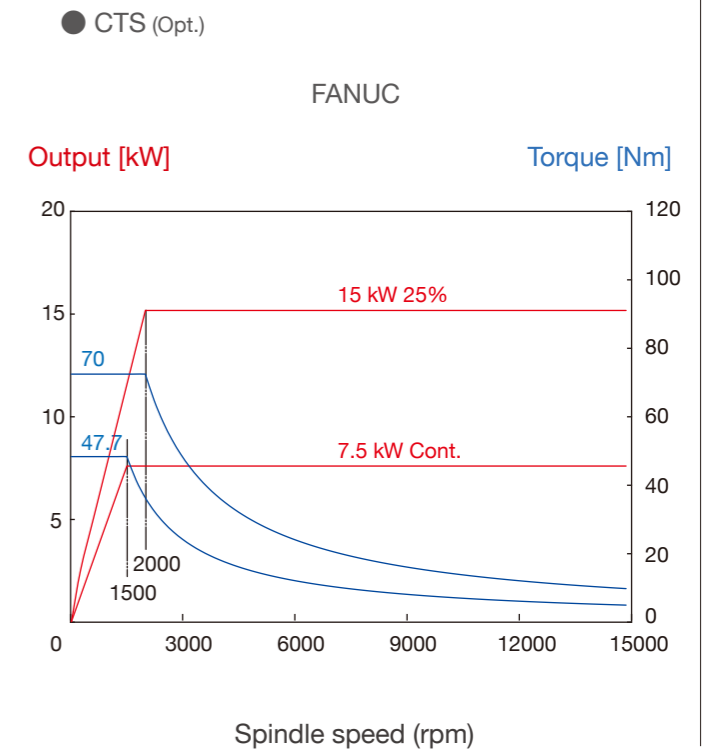
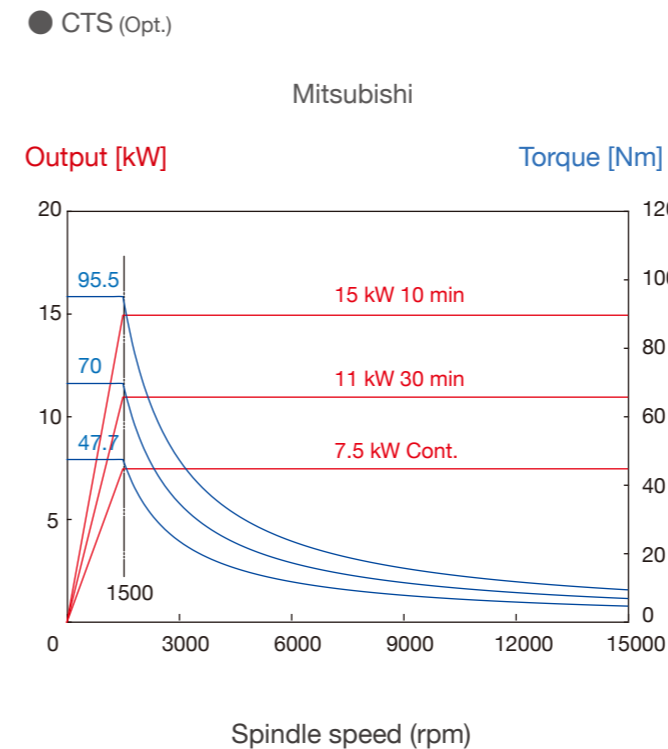

# Std. / Opt. accessories·Machine dimension

Standard ● Optional ○

Item	Std.	Opt.
LED lighting	●	
Manual pulse generator	●	
Workpiece counter (CNC)	●	
Tool magazine cover	●	
Tri-color warning light (LED)	●	
Tool magazine (24 tools)	●	
Bed flushing system	●	
Air blow system	●	
Interlock	●	
High speed and high precision control mode II (only for Mitsubishi system)	●	
Blocks in pre-read buffer (Mitsubishi M70VA)	●	
Automatic low- or high-speed winding switch(*)	●	
Nozzle coolant	●	
Air gun set	●	
280L coolant tank	●	
320L coolant tank with chip conveyor		○
Coolant gun set		○

(※ Unsuitable for SJ-V11 and βII/T12 spindle motors)

Item	Std.	Opt.
Disc type oil skimmer		○
Chip shower		○
Auger-style chip conveyor		○
Automatic door		○
Mist collector		○
Spindle oil cooler		○
Transformer/ Stabilizer		○
Tool length/breakage measurement system		○
NC rotary table		○
Hydraulic units and interface		○
FANUC fine mold machining package (AI contour control II \ blocks in pre-read buffer...)		○
Linear scale		○
Automatic power off system		○
Tool magazine (30 tools)		○
Electrical cabinet cooler		○
CE standards		○

## Machine dimension ※ VP-8(VP-10)

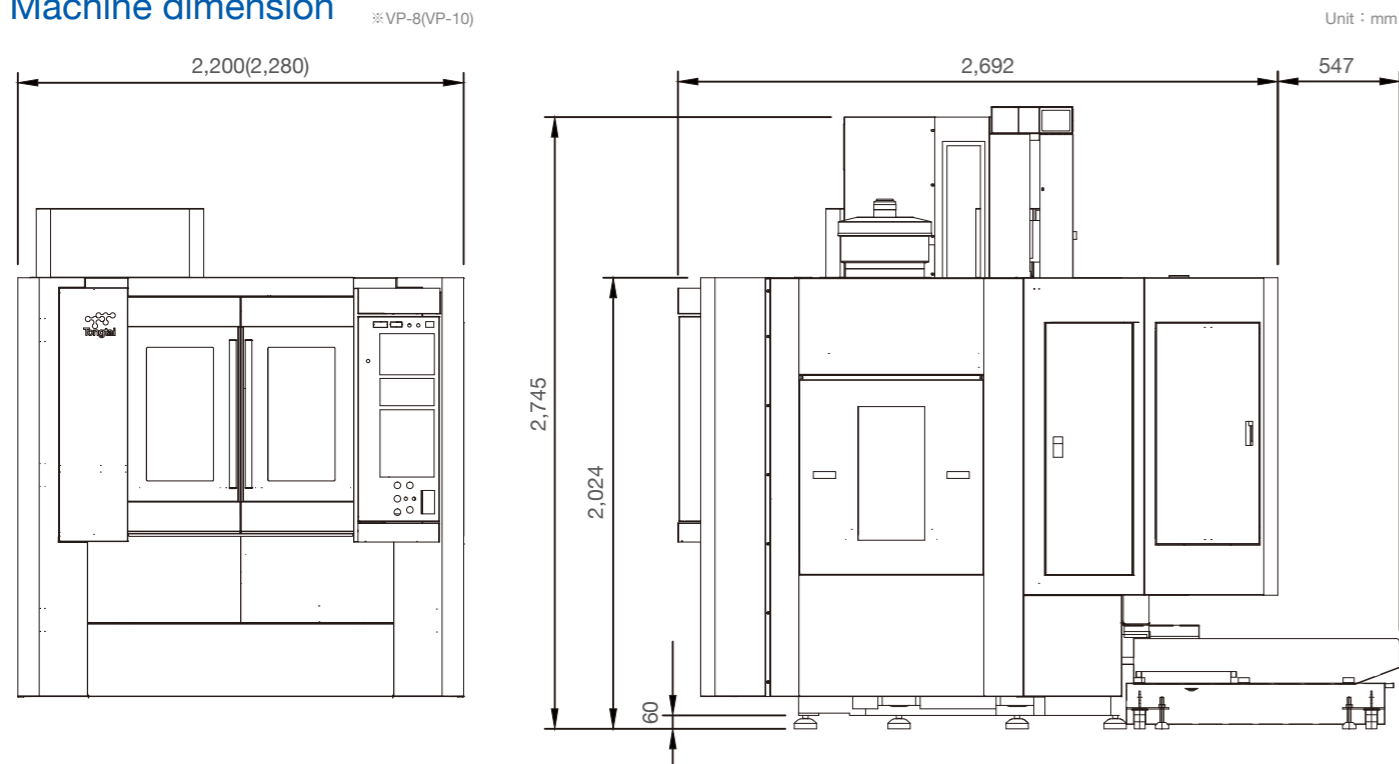

# Specification

Item	Unit	VP-8	VP-10
Type of spindle taper hole		7/24 Taper NO.40	
X/Y/Z axis Travel	mm	820/510/535	1,020/510/600
Distance from table surface to spindle gauge plane	mm	100-635	100-700
X/Y/Z axis rapid traverse rate	m/min	48/48/36	36/36/36
X/Y/Z axis cutting feedrate	mm/min	1-10,000	
Table loading capacity	kg	500	
Table size (LxW)	mm	900x510	1,070x510
T-slot		18x5	
Controller		Mitsubishi M70V TYPE A	
		FANUC 0i-F	
Tool storage capacity	pc	24 (Opt.30)	
Max. tool diameter	mm	Ø75	
Max. tool diameter (without adjacent tool)	mm	Ø150	
Max. tool length	mm	300	
Max. tool weight	kg	7	
Machine size (W x D x H)	mm	2,200x2,692x2,745	2,280x2,692x2,745
Positioning accuracy	mm	±0.005	
Repeatability	mm	±0.003	
Machine weight	kg	5,000 ±250	5,200 ±250

©Specifications may be changed without prior notice.